

Embedded Solutions

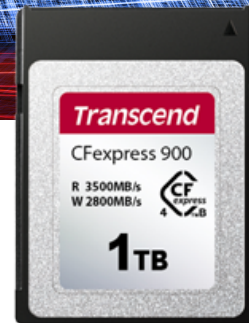

CFexpress Cards

CFE900 & CFE900I

Compliant with the CFexpress 4.0 specification, Transcend's CFexpress 900 Type B card is designed with 112-layer 3D NAND flash and a PCIe Gen 4x2 interface, offering high transfer speeds and large capacities with plug-and-play convenience. The CFexpress 900 can operate stably in temperatures ranging from -10°C to 70°C, with a wide-temperature model (-40°C to 85°C) available upon request. It is suitable for gaming machines, healthcare equipment, transportation systems, and other high-resolution image processing applications.

Hardware Features

- Compliant with CFexpress specification 4.0
- High-quality 3D NAND flash
- Promised operational reliability in a wide temperature range (from -40°C to 85°C)
- Durability: 100,000 insertion/removal cycles

Firmware Features

- Advanced Global Wear-Leveling and Block management for reliability
- Supports S.M.A.R.T. function to conduct health monitoring, analysis, and reporting for storage devices
- Built-in LDPC ECC (Error Correction Code) functionality
- Full drive encryption with Advanced Encryption Standard (AES)
- Power-saving DevSleep (Device Sleep) mode

Ordering Information

512GB	TS512GCFE900
	TS512GCFE900I
1TB	TS1TCFE900
	TS1TCFE900I

Specifications

Appearance	Dimensions	38.5 mm x 29.6 mm x 3.8 mm (1.51" x 1.16" x 0.15")
	Form Factor	CFexpress Type B
Interface	Bus Interface	NVMe PCIe Gen4 x2
Storage	Capacity	512 GB / 1 TB
	Flash Type	112-layer 3D NAND flash
Operating Environment	Storage Temperature	-40°C (-40°F) ~ 85°C (185°F)
	Humidity	0% ~ 95%
	Shock	15 G, 11 ms, 3 axis
	Vibration (Operating)	15 G (peak-to-peak), 10 Hz ~ 2000 Hz (frequency)
	Operating Temperature	Standard Temp. -10°C (14°F) ~ 70°C (158°F) Wide Temp. -40°C (-40°F) ~ 85°C (185°F)
Performance	Read Speed (Max.)	Up to 3,500 MB/s
	Write Speed (Max.)	Up to 2,800 MB/s
	Mean Time Between Failures (MTBF)	3,000,000 hour(s)
Warranty	Certificate	CE / UKCA / FCC / EAC / RCM

Mechanical Dimensions

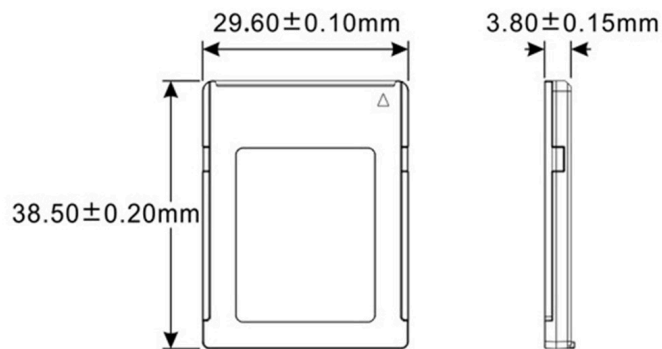

Product specifications are subject to change without notice. Pictures shown may differ from actual products. Total accessible capacity varies depending on operating environment. Due to the complexity and variety of industrial applications, Transcend cannot guarantee 100% compatibility with all platforms and under all scenarios. For special applications and environments, it is strongly suggested that you contact Transcend beforehand for clarification.